

PRODUCTION DRILLING & TAPPING SOLUTIONS

AutoDrill™

Reduce Your Costs and Increase Your Production
The Affordable, Powerful, Compact Solution

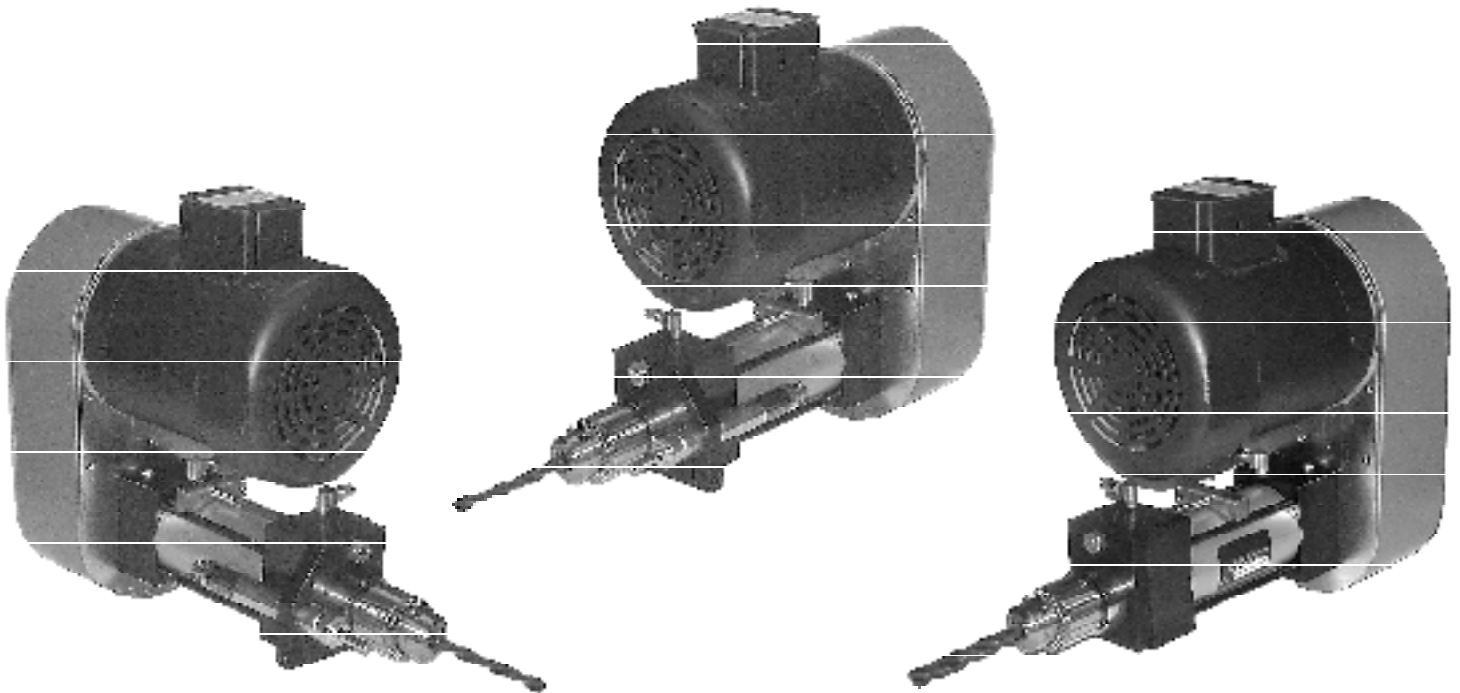

AutoDrill's OUTSTANDING FEATURES

- Self Feeding with Air or Oil
- Thrust Capacity 450 lbs. on 100 psi Shop Air
- Ratings up to 2 HP
- Spindle Speeds to 8000 RPM
- Narrow Width for Close Center Drilling
- Precision Depth Control
- Versatile Spindle & Feed Options
- All Position Mounting
- Belt Drive Standard, Other Drives Available
- Superior Warranty

Call Toll Free **800-871-5022** For an Immediate Quote!

Series 2000 AutoDrill

The Series 2000 AutoDrill is a pneumatic controlled self-feeding drill. Pneumatic stroke controls allow it to perform many basic drilling operations. Operations difficult to perform manually can be setup for continuous trouble free production.

Stroke control is usually adjusted by varying the line pressure and controlling the pneumatic flow rate.

The main features of the Series 2000 AutoDrill are:

- Self feeding capabilities with air or oil
- Thrust forces to 450 lbs. on shop air
- Maximum input torque: 80 in-lbs.
- Spindle speeds to 8000 RPM
- Stroke lengths, 2", 4" and 9"
- Narrow 3" width for close center drilling
- Built-in precision depth control
- All position mounting
- All optional accessories adaptable
- Easily upgraded to our Series 2100 AutoDrill
- Spindle input is via industrial key driven shaft
- Standard Precision Ground #33 Jacobs Spindle
- Optional #3 Jacobs, 5/8-16 & 3/4-16 Threaded Spindle

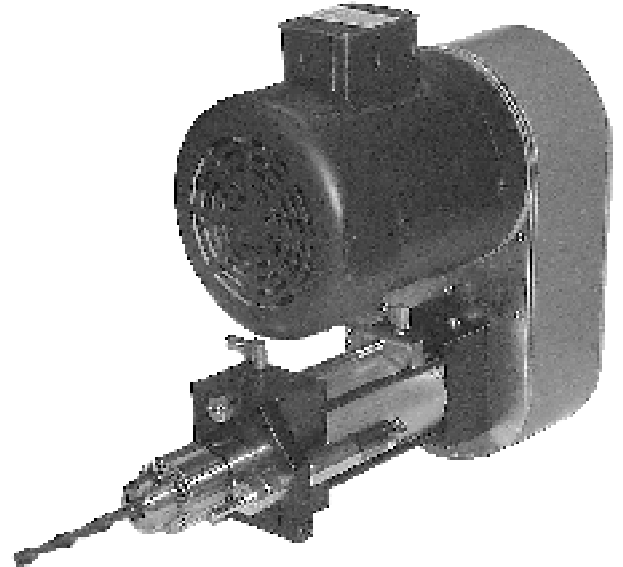

Series 2100 AutoDrill

The Series 2100 AutoDrill is based on the Series 2000 AutoDrill with the addition of a Hydro Speed feed control. This additional control is useful when a clean hole breakthrough, improved hole roundness in thin sections, large holes or when two-speed operation is desired.

Two-speed feed rate is standard. The pneumatic feed controls the less critical work approach and the Hydro Speed cylinder, when its' rod contacts the user's stop, controls the critical work penetration rate. The cylinder can be provided in any of three positions. This flexibility is appreciated when drilling closely spaced holes. Maintenance is also simplified since it can be repositioned or replaced without disturbing the AutoDrill body. The diagram below illustrates the optional locations.

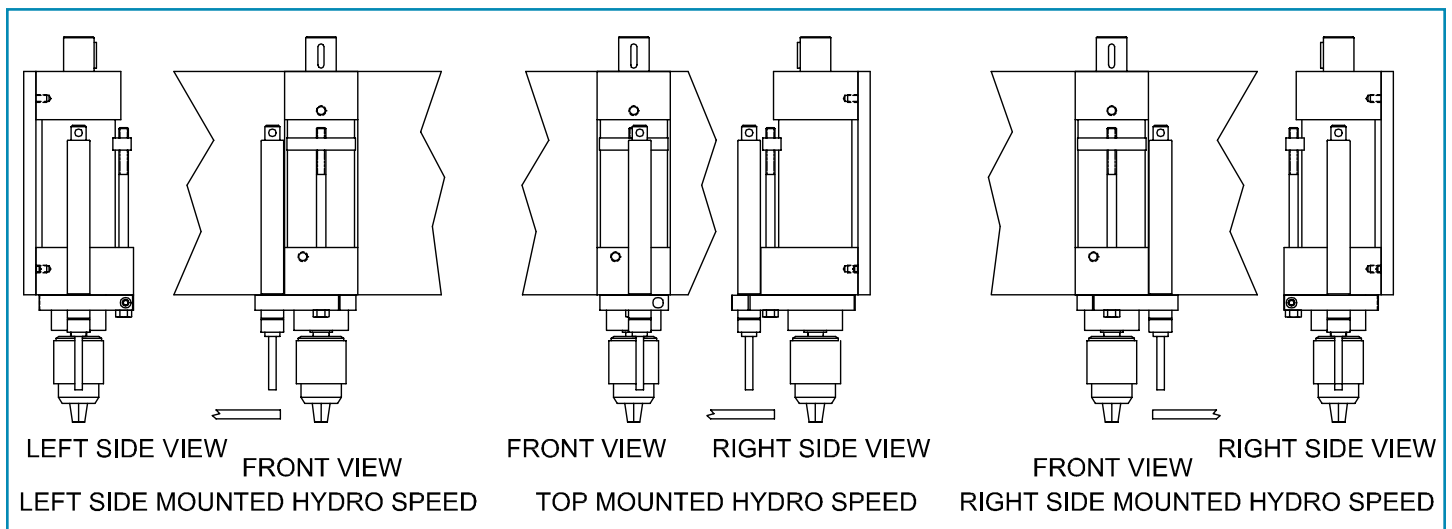

Series 2100 AutoDrill Layout

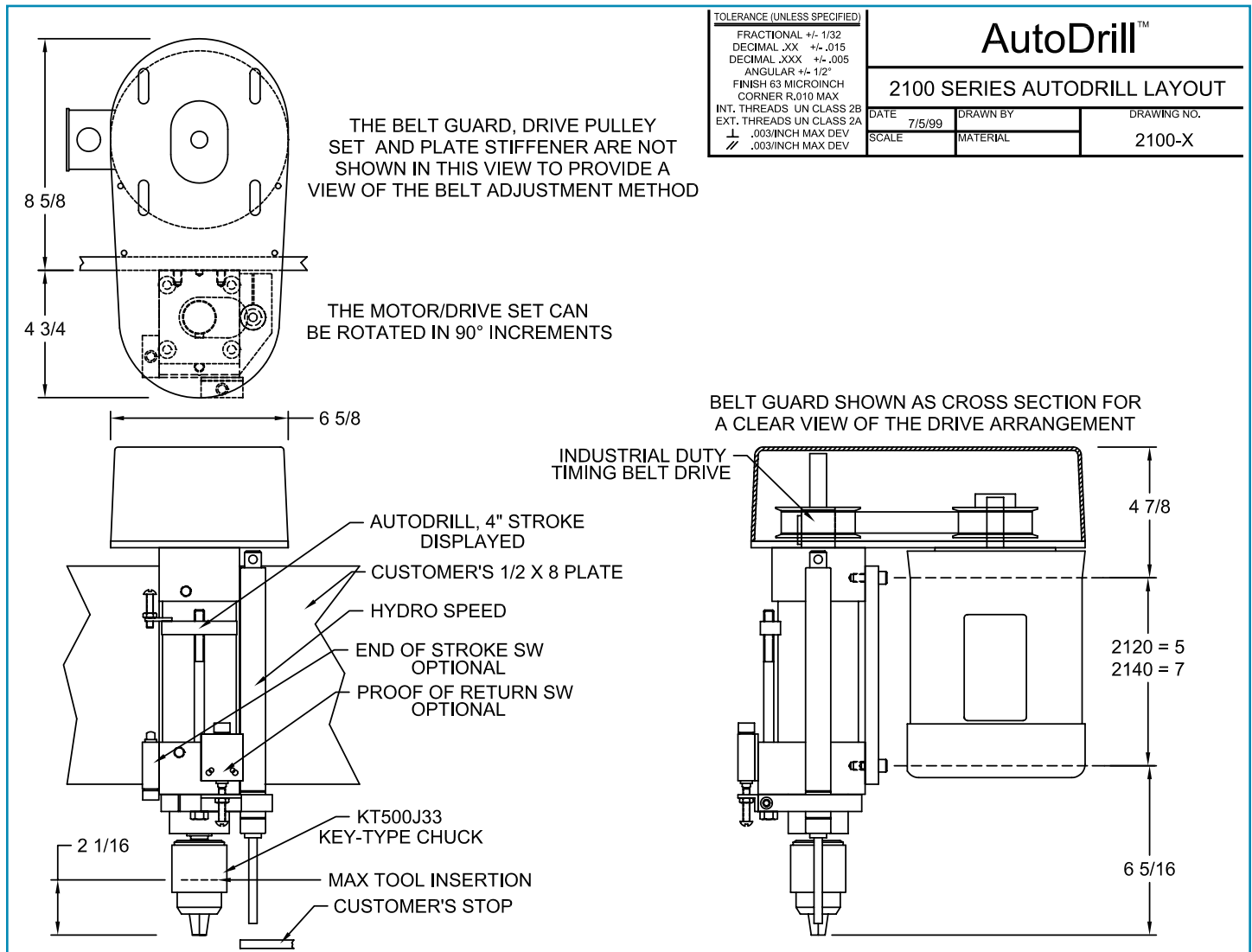

Additional guards may be necessary based on mounting arrangement and operator access to possible danger areas.

Spindle Attachments

The AutoDrill spindle accepts most industry standard attachments. Some common AutoDrill spindle attachments are:

- Professional Key-Type Chucks
- Precision Collet Chucks
- Precision Keyless Chucks
- Multiple Spindle Heads
- Self Reversing Tapping Heads

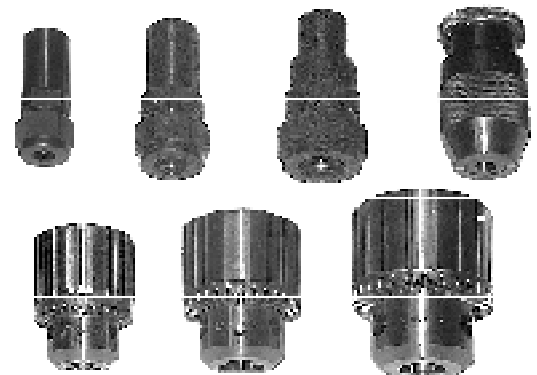

Electric Motor Drives

The Electric Drive AutoDrill offers in a compact package all the mechanical equipment to perform the most common projects. All the packages have these outstanding features:

- Industrial TEFC AC induction motor
- Pre-engineered super duty HTD belt drive with 1.5 min. S.F.
- Full coverage Safety Orange OSHA Guard
- Unitized Drill/Motor mounting
- Designed for ease of maintenance
- Simple pulley change provides wide field speed adjustment
- Flexible four position rotation design
- Minimum 4" Center to Center Available
- Minimum 3" Center to Center with Tandem Drive Option
- Available from 1/3 thru 2 HP, Single or Three Phase
- Standard "U" arrangement, optional "Z" arrangement



Drive Selection

HP	Range Spindle RPM	Arrangement			
		U		Z	
		115/230 Volt, 1Ø	230/460 Volt, 3Ø	115/230 Volt, 1Ø	230/460 Volt, 3Ø
1/3	High 2500-4800	BD33XXXXU-1A	BD33XXXXU-3A	BD33XXXXZ-1A	BD33XXXXZ-3A
1/2	High 2500-4800	BD50XXXXU-1A	BD50XXXXU-3A	BD50XXXXZ-1A	BD50XXXXZ-3A
	Medium 1055-2499	BD50XXXXU-1B	BD50XXXXU-3B	BD50XXXXZ-1B	BD50XXXXZ-3B
	Low 570-1054	BD50XXXXU-1C	BD50XXXXU-3C	BD50XXXXZ-1C	BD50XXXXZ-3C
3/4	Medium 1055-2499	BD75XXXXU-1B	BD75XXXXU-3B	BD75XXXXZ-1B	BD75XXXXZ-3B
	Low 570-1054	BD75XXXXU-1C	BD75XXXXU-3C	BD75XXXXZ-1C	BD75XXXXZ-3C
1	Medium 1055-2499	—	BD10XXXXU-3B	—	BD10XXXXZ-3B
	Low 570-1054	—	BD10XXXXU-3C	—	BD10XXXXZ-3C
1 1/2	Medium 1055-2499	—	BD15XXXXU-3B	—	BD15XXXXZ-3B
	Low 570-1054	—	BD15XXXXU-3C	—	BD15XXXXZ-3C

XXXX is the Spindle RPM

Consult Engineering for special motors and lower speeds. Ask for the free CAD disk.

Pneumatic Automation Controls

We offer our Standard Cycle Control, which handles most common applications. The outstanding features are:

- Completely pneumatic, no electrical wiring required
- Pre-engineered, pre-piped, adjusted and tested to save time
- Standard 1/4" NPT inlet for convenience and best performance
- Operator Start can be mounted in any convenient location
- Mounting brackets included
- Tubing for field connections & air tool lubrication provided for your convenience
- Standard options are easily integrated into the system

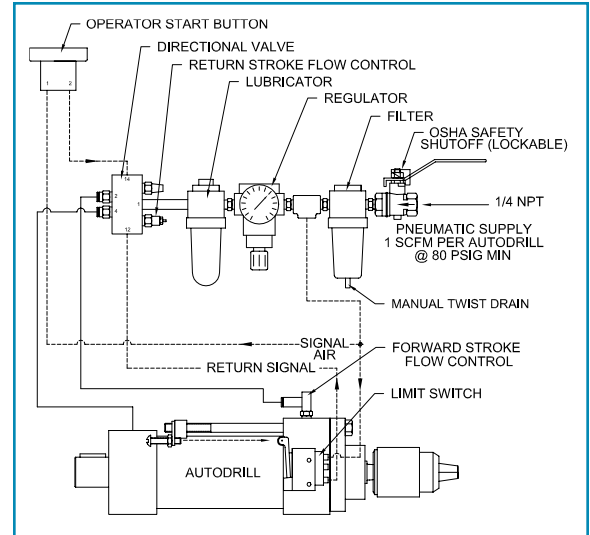

Pneumatic Control Options

Standard Cycle Control

Safety Shut-off, Filter, Regulator/Guage, Lubricator, Four Way Directional Valve, Start Operator, Exhaust Filter/Muffler, Flow Controls, Piping, Tubing, Assembly and Testing for a Single AutoDrill

Standard Cycle Control Unit Adder

Additional components for each additional AutoDrill when operated as a set

Foot Pedal Option

Pneumatic foot pedal assembled with OSHA foot guard, assembly fittings, hose, etc

Two Hand Anti-TieDown Control Option

Momentary two hand start option. Both operators must be depressed within .4 seconds to start the drill cycle. Buttons may be released immediately after the start.

Maintained Two Hand Anti-TieDown Control Option

Simultaneous operation of two operators within .5 seconds and the CONTINUOUS depression of the operators throughout the forward drilling cycle is required for operation with this option.

Sequencing Option

Control of two operations where the second operation starts immediately after the first. All the switching and timing parts, assembly and testing are included for one pair of related operations.

Peck Drill Control

Holes deeper than 5-6X the drill diameter may require "Peck Drilling" to clear chips, minimize drill breakage and provide satisfactory hole precision. AutoDrill's Peck Drill Control provides the timing/depth sequence for precision deep hole drilling. Adjustable extend and retract timers and our "Memory" Hydro Feed are the key components. The standard Peck Drill Control is based on pneumatic logic. A more sophisticated PLC based control is also available. Our engineering and process experience simplifies this delicate operation.

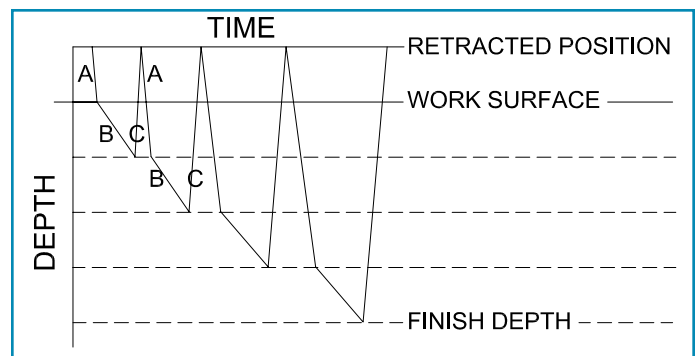

A - Rapid Extension B - Precision Drilling C - Retracting/Chip Removal

IMPORTANT: Controls are designed to operate **AutoDrill** pneumatic equipment. It is the customer's responsibility to determine the proper application, use and mounting of the equipment. All operations should be reviewed by a qualified safety person before any equipment is made operational.

Self-Feed AutoTaps

The Self-Feed AutoTap is based on the standard AutoDrill with the addition of a Self-Reversing Tapping Head. This allows a single unit to be used for both drilling and tapping. The AutoTap is capable of any thread configuration within its capacity range. This keeps the cost reasonable. No longer is it necessary to have an individual lead screw for each thread pitch. All Self-Feed AutoTaps have these outstanding features:

- Positive Forward and Reverse Drive
- Entry Cushion for reliable work contact and elimination of cross threading on rethreading operations
- Three Models handle #6 thru 5/8" capacity
- Operator Tool Package included
- Available with Rubber-Flex Collet as standard or with Optional Quick Change Spindle
- Short Stroke Self-Feed compensates for minor feed errors
- Factory Assembled and Tested

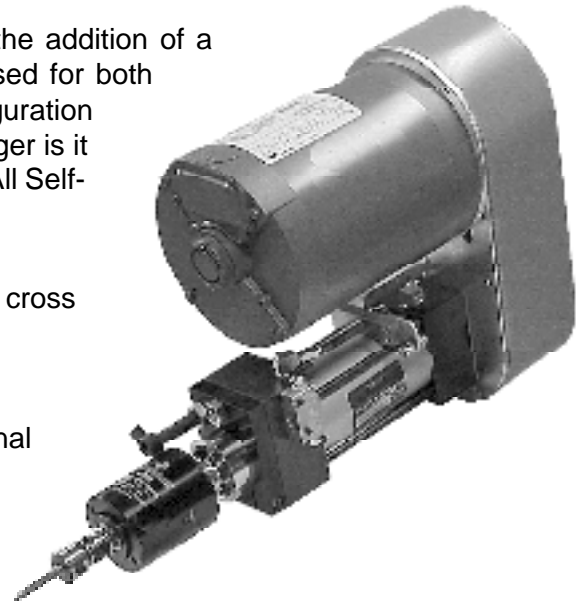

AutoTap Selection

AutoTap Unit	Mount	Capacity	Rubber-Flex Collet	Tap Shank Size
SPD3J33	#33 JT	#6 - #8 #10 - 1/4"	21600 21700	.098 - .177 .177 - .256
SPD5J33	#33 JT	#6 - 1/4" 1/4" - 1/2"	22100 22200	.139 - .257 .253 - .383
SPD7J3	#3 JT	#10 - 1/2" 5/16" - 5/8"	24100 24000	.176 - .383 .280 - .500

Tapping Parameter Guidelines

Material	Size	#6	#8	#10	1/4	5/16	3/8	1/2	5/8
Aluminum	RPM	1800	1700	1600	1400	1200	800	600	500
	HP	.06	.06	.06	.15	.19	.23	.34	.48
Brass	RPM	1800	1700	1600	1400	1200	800	600	500
	HP	.09	.09	.09	.22	.29	.35	.50	.70
Cast Iron	RPM	1500	1400	1300	1100	850	700	500	400
	HP	.12	.13	.14	.35	.43	.53	.77	1.09
Low Carbon Steel	RPM	1200	1100	1050	900	700	550	400	325
	HP	.16	.17	.18	.47	.56	.70	1.00	1.43
Stainless Steel	RPM	700	650	600	500	400	350	275	225
	HP	.15	.16	.17	.44	.54	.66	.96	1.35
Plastic	RPM	1800	1700	1600	1400	1200	800	600	500
	HP	.06	.06	.06	.15	.19	.23	.34	.48

Parameters are based upon average conditions. Coarse pitch taps tend to be below and fine pitch taps above the recommended speeds.

Selecting an AutoDrill System

AutoDrill systems usually include the following components:

- 1) AutoDrill Self-Feed Unit
- 2) Spindle Attachment
- 3) Spindle Drive
- 4) Control Components

Determining Your Requirements:

- 1) Select the 2000 Series or 2100 Series Self-Feed Unit depending on your precision and stroke requirements.
- 2) Choose your Spindle Attachment.
- 3) Determine the Horsepower, Spindle Speed and Thrust recommended from the “Drill Parameter” chart. The Spindle Drive can then selected from the “Drive Selection” chart.
- 4) Choose a Pre-Engineered Control System to control the stroke and sequencing of the system. Optional accessories, such as Position Switch Kits are available to integrate the system with other operations or PLC controls.

IMPORTANT NOTE: The above selection criteria is provided for your information. Our Sales and Engineering staff will be happy to recommend the AutoDrill System for your project. All components are factory assembled and tested. Field connections are clearly marked. Our “Safety, Installation, Operating and Maintenance” Manual is shipped with each system.

High Speed Drill Parameter Chart

Material	Dia., in.	1/16	1/8	3/16	1/4	5/16	3/8	1/2	5/8	3/4	1
Aluminum	RPM	10,000	6000	4000	3000	2400	2000	1500	1200	1000	750
	HP	.01	.07	.10	.20	.28	.38	.67	1.00	1.37	2.30
	Feed, in/rev.	.001	.003	.005	.007	.008	.009	.012	.014	.016	.018
	Thrust, lbs.	6	25	50	80	100	125	200	260	335	450
Brass	RPM	10,000	6000	4000	2400	1800	1500	1200	900	750	600
	HP	.01	.05	.10	.18	.28	.35	.55	.80	1.10	1.80
	Feed, in/rev.	.001	.002	.003	.004	.005	.006	.008	.010	.012	.014
	Thrust, lbs.	10	25	45	70	100	135	215	295	395	525
Cast Iron	RPM	6000	3000	2000	1450	1150	975	725	600	500	375
	HP	.01	.04	.11	.18	.28	.38	.57	.80	1.10	1.75
	Feed, in/rev.	.001	.002	.004	.005	.006	.007	.008	.009	.010	.012
	Thrust, lbs.	15	40	100	150	200	260	350	480	550	800
Low Carbon Steel	RPM	4300	2150	1450	1100	900	750	550	450	360	275
	HP	.01	.05	.12	.20	.30	.35	.68	1.05	1.50	2.10
	Feed, in/rev.	.001	.003	.005	.007	.008	.009	.012	.014	.016	.018
	Thrust, lbs.	30	80	145	230	340	440	700	1050	1300	2000
Stainless Steel	RPM	3200	1550	1025	775	620	510	400	310	360	270
	HP	.01	.05	.12	.21	.40	.48	.85	1.45	2.05	3.1
	Feed, in/rev.	.001	.002	.003	.004	.005	.005	.007	.009	.010	.011
	Thrust, lbs.	40	100	180	290	425	465	780	1100	1500	1900
Plastic/Wood	RPM	7000	4000	2700	2000	1600	1400	1000	800	700	550
	HP	.01	.07	.10	.12	.14	.16	.20	.30	.42	.70
	Feed, in/rev.	.001	.002	.003	.004	.004	.005	.007	.009	.011	.015
	Thrust, lbs.	10	20	40	60	70	90	145	175	220	330

Parameters are based upon average conditions. Special conditions, such as deep hole drilling may be different.

Series 2000 AutoDrill Specifications

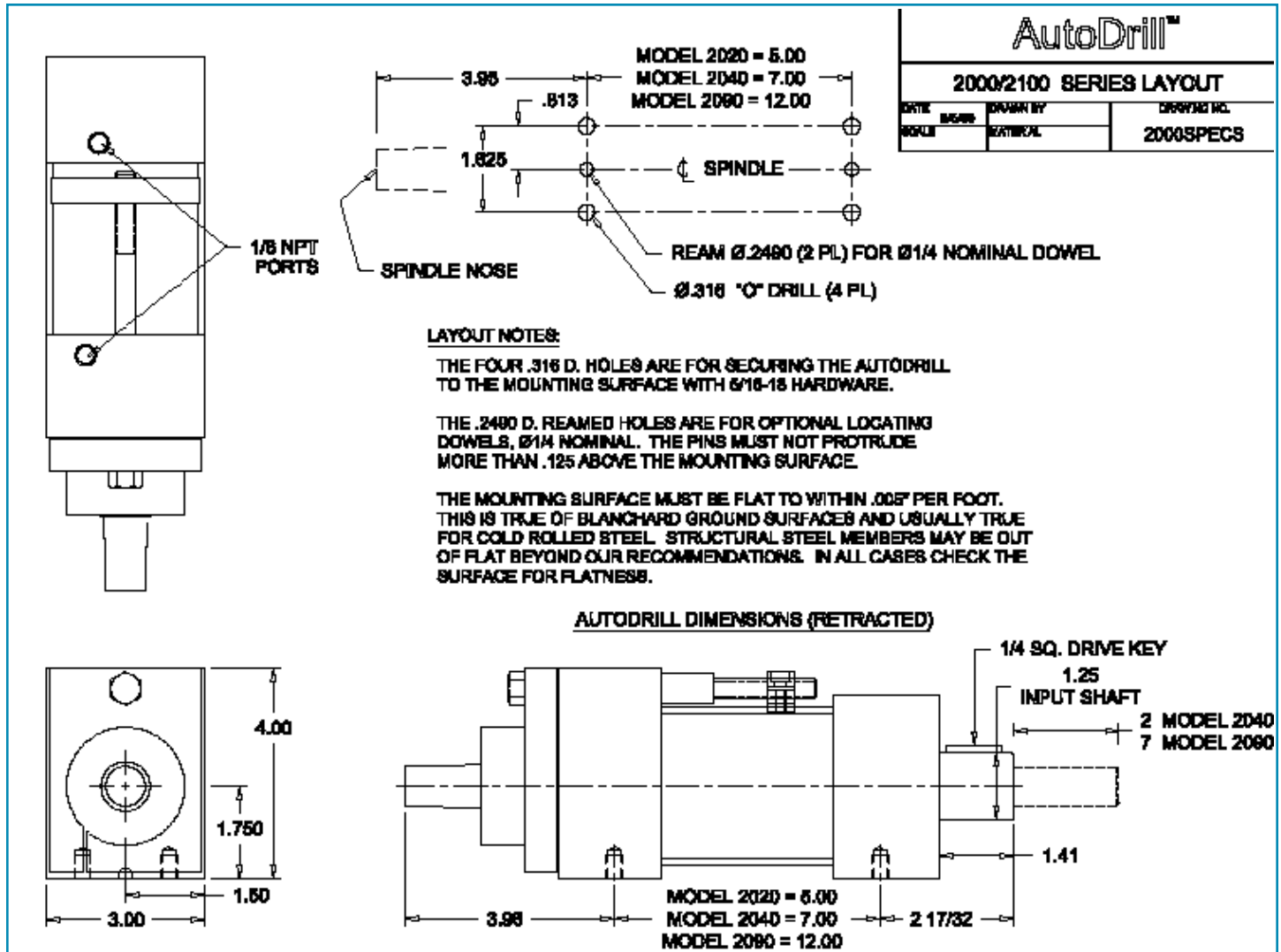

All AutoDrill product information is available in electronic format. Computer Aided Design drawings are available in AutoCad DWG R12, DWG R13, DWG R14 and DXF R12 formats.

Ask for More Information on Our Accessories:

- Fixture Stands • Work Clamping • Guide Bushing Plates • Position Slides • Engineering Services

AutoDrill™

50 Division Avenue
 Millington, New Jersey 07946

PHONE: 800-871-5022
 WEBSITE: www.AutoDrill.com

FAX: 908-542-0242
 E-MAIL: sales@AutoDrill.com